

2.2 Range of usage & limitations

Item	Models	
	SRK20ZG-S, 25ZG-S, 35ZG-S	SRK50ZG-S
Indoor return air temperature (Upper, lower limits)	Cooling operation : Approximately 18 to 32°C Heating operation : Approximately 15 to 30°C	
Outdoor air temperature (Upper, lower limits)	Cooling operation : Approximately -15 to 46°C Heating operation : Approximately -15 to 21°C	
Refrigerant line (one way) length	Max. 15m	Max. 25m
Vertical height difference between outdoor unit and indoor unit	Max. 10m (Outdoor unit is higher) Max. 10m (Outdoor unit is lower)	Max. 15m (Outdoor unit is higher) Max. 15m (Outdoor unit is lower)
Power source voltage	Rating \pm 10%	
Voltage at starting	Min. 85% of rating	
Frequency of ON-OFF cycle	Max. 4 times/h (Inching prevention 10 minutes)	Max. 7 times/h (Inching prevention 5 minutes)
ON and OFF interval	Max. 3 minutes	

2.3 Exterior dimensions

(1) Indoor unit

Models SRK20ZG-S, 25ZG-S, 35ZG-S, 50ZG-S

Unit: mm

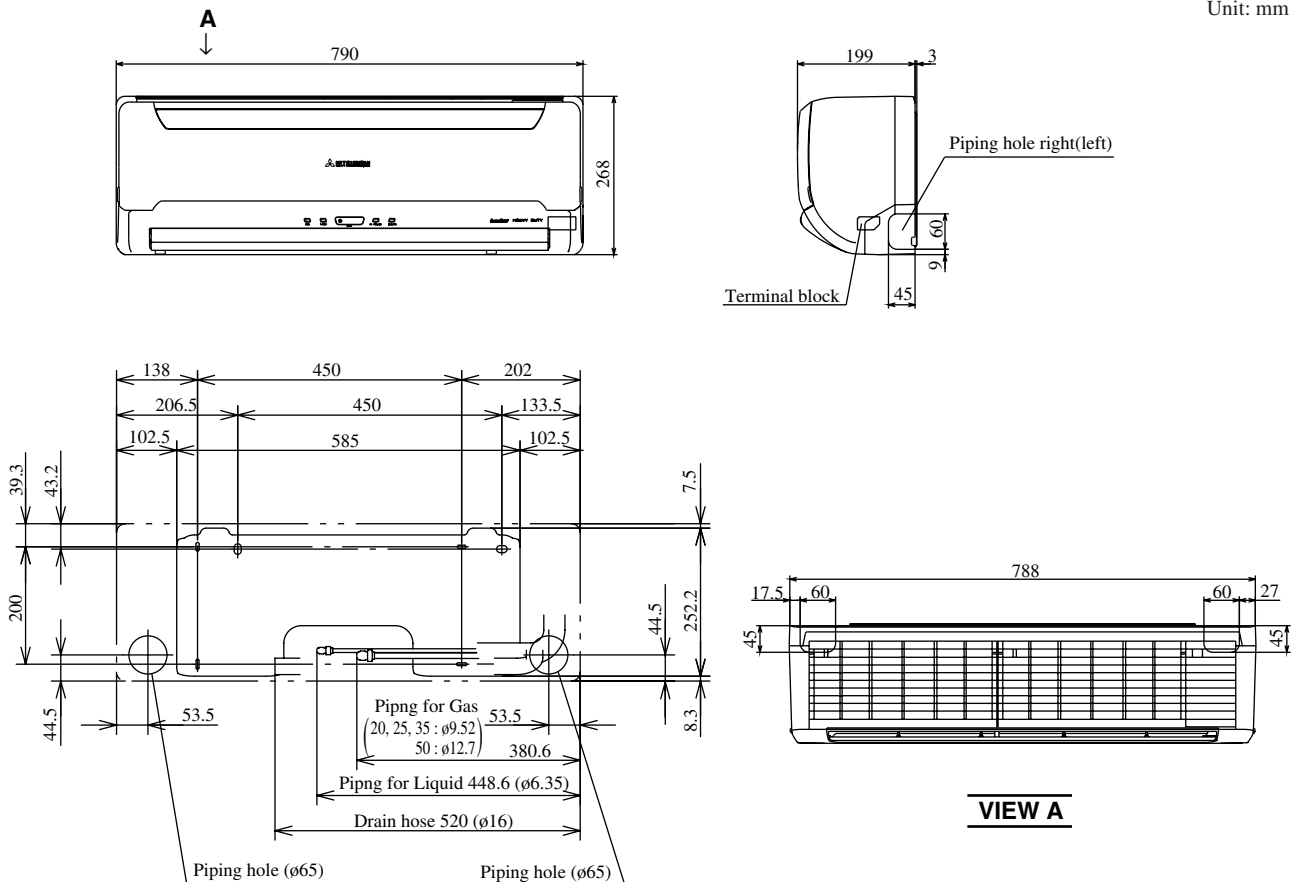

(2) Outdoor unit

Models SRC20ZG-S, 25ZG-S, 35ZG-S

Unit: mm

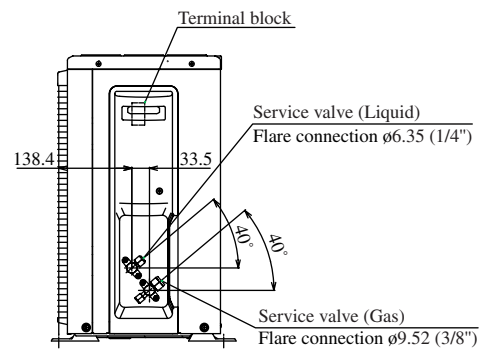
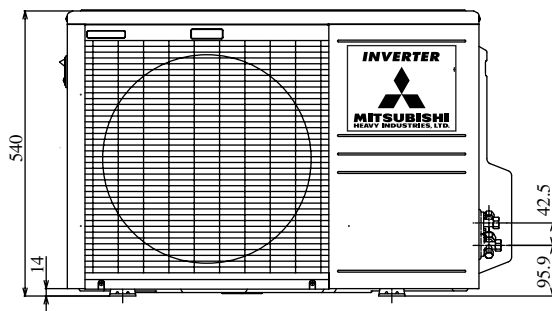
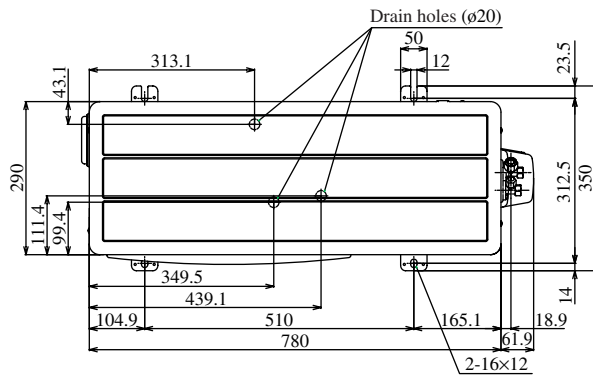

Model SRC50ZG-S

